



Cambridge International Examinations
Cambridge International General Certificate of Secondary Education

COMBINED SCIENCE

0653/12

Paper 1 Multiple Choice

May/June 2015

45 minutes

Additional Materials: Multiple Choice Answer Sheet
Soft clean eraser
Soft pencil (type B or HB is recommended)



READ THESE INSTRUCTIONS FIRST

Write in soft pencil.

Do not use staples, paper clips, glue or correction fluid.

Write your name, Centre number and candidate number on the Answer Sheet in the spaces provided unless this has been done for you.

DO NOT WRITE IN ANY BARCODES.

There are **forty** questions on this paper. Answer **all** questions. For each question there are four possible answers **A, B, C** and **D**.

Choose the **one** you consider correct and record your choice in **soft pencil** on the separate Answer Sheet.

Read the instructions on the Answer Sheet very carefully.

Each correct answer will score one mark. A mark will not be deducted for a wrong answer.

Any rough working should be done in this booklet.

A copy of the Periodic Table is printed on page 20.

Electronic calculators may be used.

This document consists of **18** printed pages and **2** blank pages.

1 The diagram shows a palisade cell.

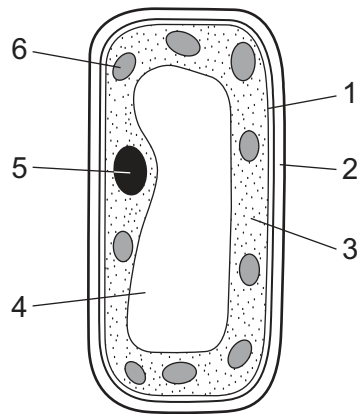

Which parts are found in plant cells and **not** in animal cells?

	1	2	3	4	5	6
A	✓	x	✓	✓	x	x
B	✓	x	✓	x	✓	x
C	x	✓	x	✓	x	✓
D	x	✓	x	x	✓	✓

2 The diagram shows a biological specimen as viewed through a light microscope.

The scale is in mm.

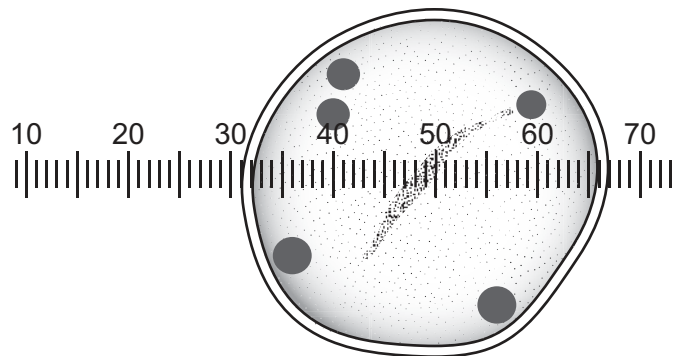

What is the diameter of the specimen?

- A** 28 mm **B** 31 mm **C** 36 mm **D** 67 mm

3 Which substances may diffuse into and out of plant cells?

	into plant cells	out of plant cells
A	chlorophyll	oxygen
B	oxygen	water
C	starch	chlorophyll
D	water	starch

4 The numbered statements are about enzymes.

- 1 All enzymes are proteins.
- 2 Enzymes are destroyed at temperatures below 5 °C.
- 3 Enzymes speed up the rate of chemical reactions.
- 4 The higher the pH the faster the enzymes work.

Which statements are correct for **all** enzymes?

- A** 1 and 2 **B** 1 and 3 **C** 2 and 3 **D** 3 and 4

5 The table names some places where processes involved in animal nutrition may take place.

Which row is correct?

	ingestion	digestion
A	mouth	mouth cavity
B	mouth	pancreas
C	oesophagus	ileum
D	oesophagus	stomach

6 In transpiration, most of the water evaporates at the surface of which part of a leaf?

- A** epidermis
- B** guard cells
- C** mesophyll
- D** xylem

- 7 Which statement about respiration is **not** correct?
- A Respiration always releases energy.
 - B Respiration in green plants does not use oxygen.
 - C Respiration occurs only in living cells.
 - D Respiration provides energy for muscle contraction

- 8 The diagram shows the volume of air in the lungs over a period of 30 s for a person at rest.

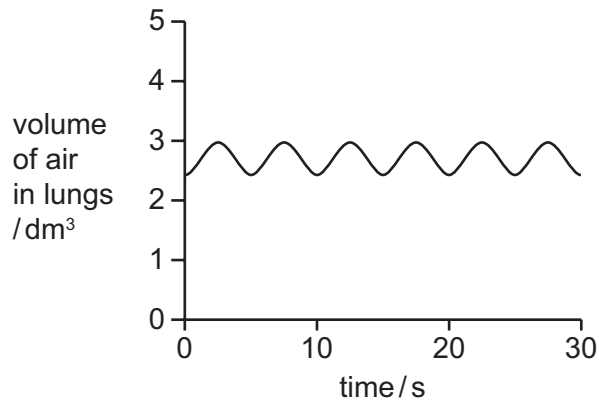

The following graphs show the volume of air in the lungs over a similar period of time when the same person is no longer at rest.

Which graph records the rate and depth of breathing during vigorous activity?

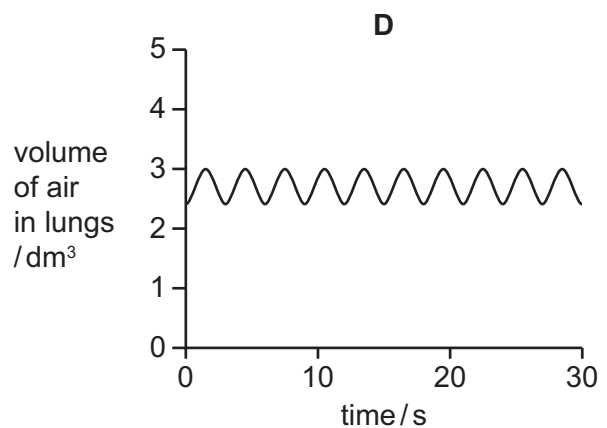
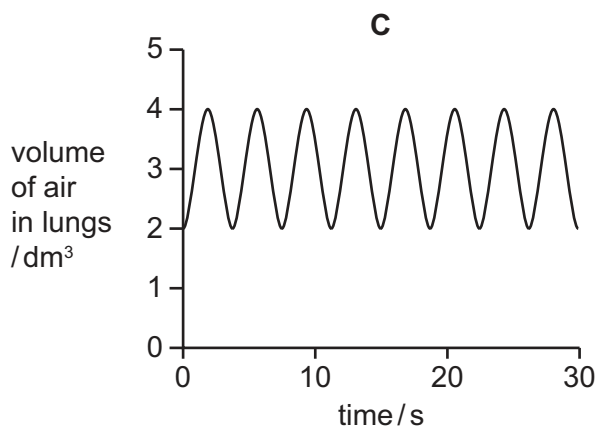
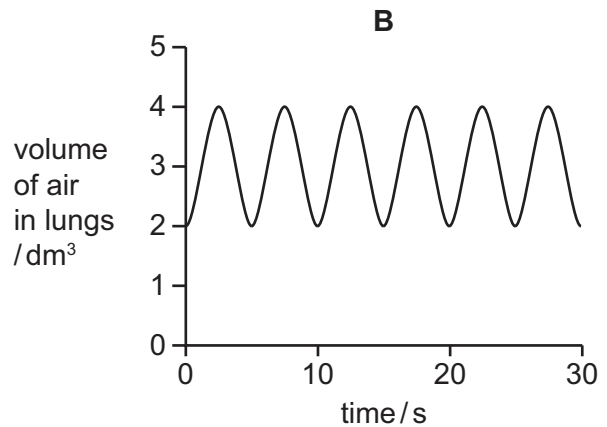
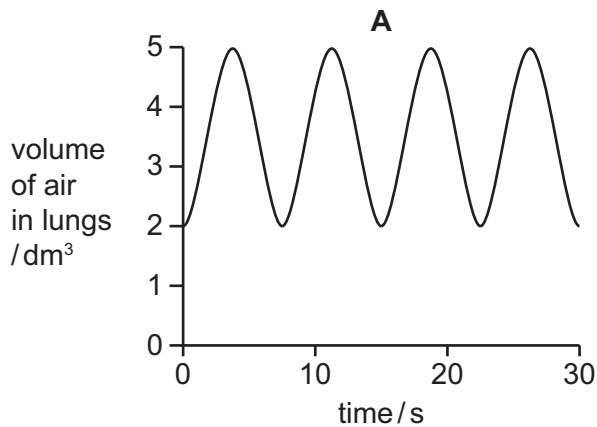

9 A healthy person does not eat for several hours but then has a meal rich in carbohydrate.

Which graph shows how the person's blood sugar level changes after the meal?

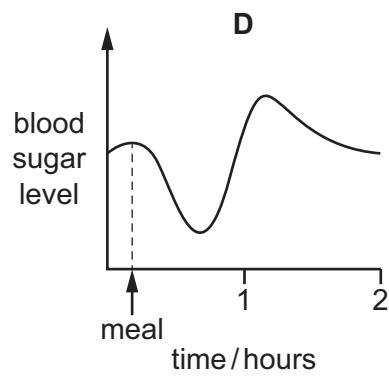
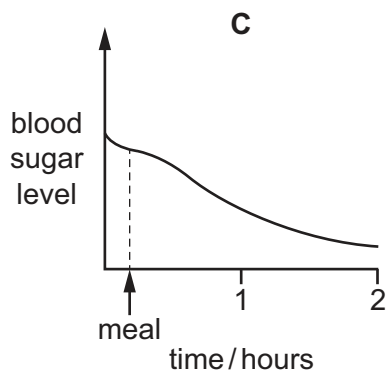
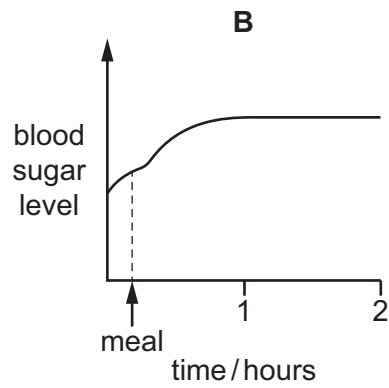
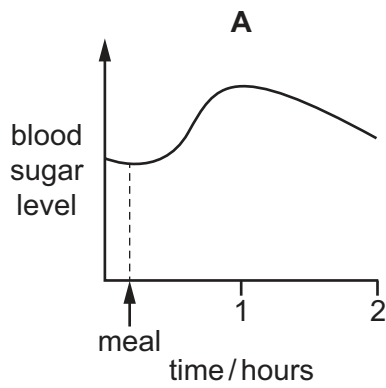

10 What is the stimulus for geotropism in plants?

- A gravity
- B light
- C temperature
- D water

11 The diagram shows a side view of the female reproductive system in a human.

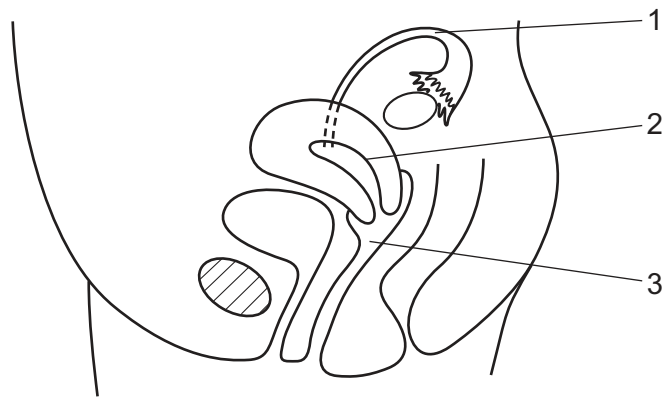

Where do fertilisation and implantation occur?

	fertilisation	implantation
A	1	2
B	2	1
C	2	3
D	3	2

12 What are features of asexual reproduction?

	number of parents	presence of gametes	production of a zygote
A	1	✓	✓
B	1	x	x
C	2	✓	x
D	2	x	✓

13 A farmer makes his grass grow more quickly by adding cow manure to the soil. He feeds this grass to the same cows and milks the cows.

Which is the producer in this food chain?

- A** the cows
- B** the farmer
- C** the grass
- D** the manure

14 How many atoms of hydrogen are present in three molecules of ammonia, NH_3 .

- A 3 B 6 C 9 D 12

15 Which processes are involved in the separation of petroleum?

- A condensation and crystallisation
 B condensation only
 C evaporation and condensation
 D evaporation only

16 Fluorine and chlorine are in Group VII of the Periodic Table.

Which number increases by eight from fluorine to chlorine?

- A the number of atoms in one molecule
 B the number of electrons in one atom
 C the number of electrons in one molecule
 D the number of nucleons in one atom

17 The structure of a compound is shown.

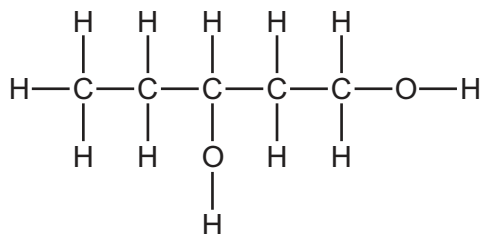

What is the formula of the compound?

- A $\text{C}_5\text{H}_{11}\text{O}$ B $\text{C}_5\text{H}_{11}\text{O}_2$ C $\text{C}_5\text{H}_{12}\text{O}$ D $\text{C}_5\text{H}_{12}\text{O}_2$

18 The diagram shows the electrolysis of molten lead(II) bromide.

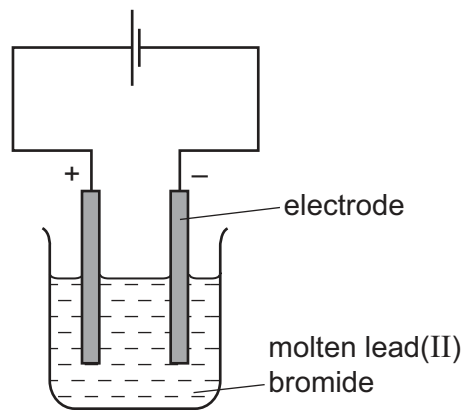

Which row is correct?

	name of positive electrode	product at the negative electrode
A	anode	bromine
B	anode	lead
C	cathode	bromine
D	cathode	lead

19 A student measures the initial and final temperatures of four different reactions.

Which reaction is endothermic?

	initial temperature / °C	final temperature / °C
A	2	20
B	20	20
C	22	42
D	30	27

- 20 The diagram shows equal masses of magnesium added to equal volumes of acid of the same concentration.

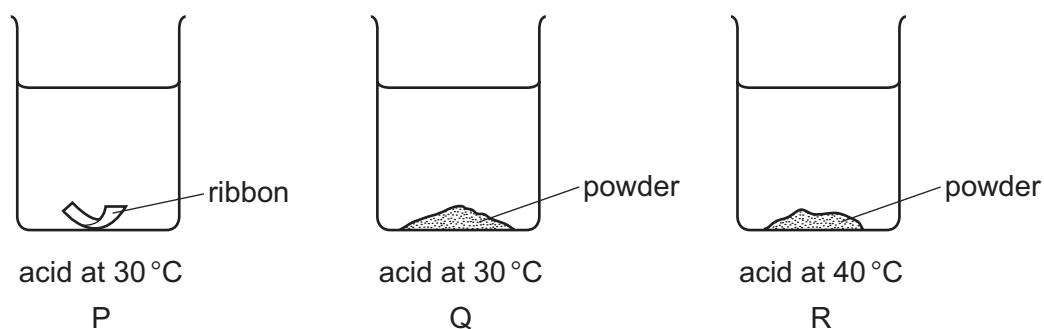

What is the order of the speed of reaction?

	fastest	→	slowest
A	P	R	Q
B	Q	R	P
C	R	P	Q
D	R	Q	P

- 21 Magnesium reacts with carbon dioxide to give magnesium oxide and carbon.

What happens to the magnesium?

- A** It is oxidised by gaining oxygen.
B It is oxidised by losing oxygen.
C It is reduced by gaining oxygen.
D It is reduced by losing oxygen.

- 22 The table shows the results of tests on an aqueous solution of X.

test	result
blue litmus paper	turns red
aqueous silver nitrate	white precipitate formed

What is X?

- A** HCl **B** HNO_3 **C** NaCl **D** NaOH

23 Lithium is a metal in Group I of the Periodic Table.

Which statement about lithium is correct?

- A It is hard with the highest melting point in Group I.
- B It is hard with the lowest melting point in Group I.
- C It is soft with the highest melting point in Group I.
- D It is soft with the lowest melting point in Group I.

24 A new alloy is resistant to corrosion.

It costs about the same as aluminium but it is slightly poisonous.

Its density, compared with stainless steel and aluminium, is shown.

	aluminium	new alloy	stainless steel
<u>density</u> g/cm ³	2.7	2.8	7.9

What is this new alloy used to make?

- A aircraft frames
- B cutlery
- C electrical insulators
- D food containers

25 The diagram shows an element being added to cold water to form a gas and an alkaline solution.

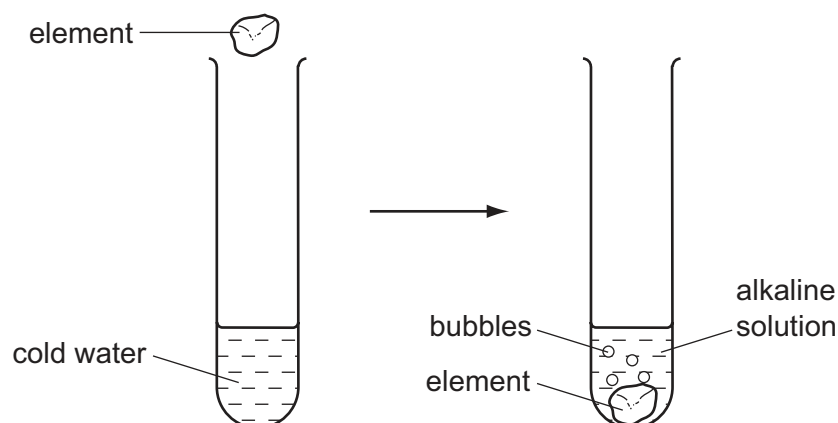

What is the element?

- A calcium
- B carbon
- C copper
- D sulfur

26 Carbon is used to extract copper from copper oxide.

Which statement about the process is correct?

- A Carbon is an oxidising agent.
- B Carbon is more reactive than copper.
- C Copper is more reactive than carbon.
- D Copper oxide is a reducing agent.

27 Iron rusts when it reacts with oxygen and water.

Which substances are used to prevent rusting?

	oil	paint	zinc	
A	✓	✓	✓	key ✓ = yes x = no
B	✓	✓	x	
C	✓	x	✓	
D	x	✓	✓	

28 An ant walks a distance of 90 cm in a time of 1 minute at a steady speed.

What is its speed?

- A 0.011 cm/s
- B 0.67 cm/s
- C 1.5 cm/s
- D 90 cm/s

29 A shop-keeper places **two** identical blocks of cheese on a balance.

The combined mass of the two blocks of cheese is 240 g.

Each block measures 2.0 cm × 5.0 cm × 10.0 cm.

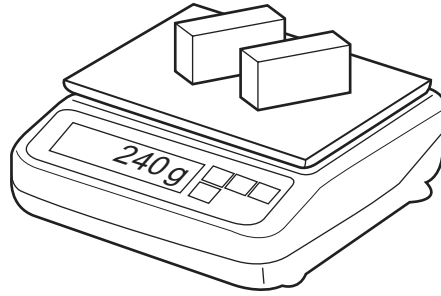

What is the density of the cheese?

- A 0.42 g/cm³ B 0.83 g/cm³ C 1.2 g/cm³ D 2.4 g/cm³

30 A car is driven on a long journey along a horizontal road. The car stops several times on the journey and its engine becomes hot.

Which type of energy remains constant during the journey?

- A the chemical energy in the fuel tank
B the gravitational energy of the car
C the kinetic energy of the car
D the thermal energy of the engine

31 Which statement about the evaporation of a liquid is **not** correct?

- A Evaporation happens only at one particular temperature.
B Evaporation happens only at the surface of the liquid.
C Evaporation happens when the more energetic molecules escape from the liquid.
D The energy required for evaporation can cause the liquid to cool.

- 32 Hot, liquid wax is allowed to cool to room temperature. The graph shows how the temperature of the wax changes with time.

At which labelled point on the graph are both liquid wax and solid wax present?

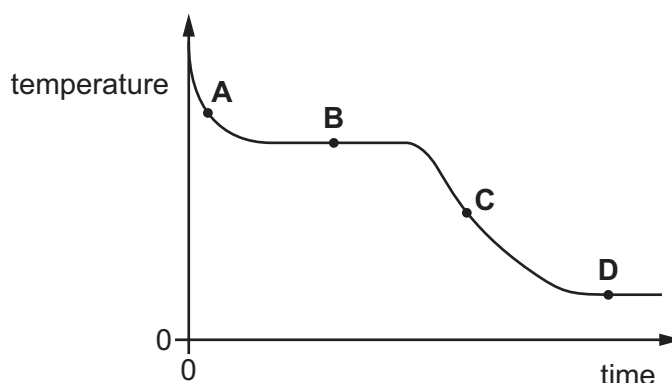

- 33 Which row is correct?

	conduction of heat	convection of heat
A	can happen in a solid	can happen in a solid
B	can happen in a solid	only happens in liquids and gases
C	only happens in liquids and gases	can happen in a solid
D	only happens in liquids and gases	only happens in liquids and gases

- 34 A boat floats on the sea. The boat moves slowly up and down as a wave passes it. The amplitude of the wave is 0.50 m.

What is the vertical distance between the highest and lowest positions of the boat as the wave passes it?

- A** 0 m **B** 0.50 m **C** 1.0 m **D** 2.0 m

35 The diagram shows three rays of light passing through a converging lens.

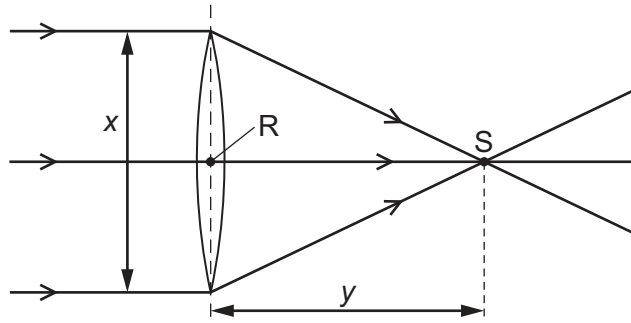

Which labelled point is the principal focus of the lens, and which labelled distance is the focal length of the lens?

	principal focus	focal length
A	R	x
B	R	y
C	S	x
D	S	y

36 A filament lamp is used in a zoo to keep young animals warm.

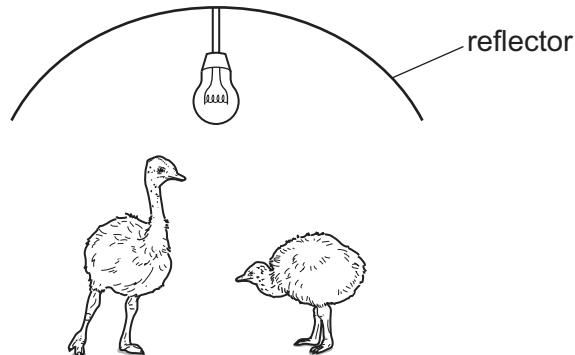

What are the main types of wave given out by the lamp?

- A** visible light and infra-red
- B** visible light and microwaves
- C** visible light and radio waves
- D** visible light and X-rays

37 A loudspeaker vibrates with different amplitudes and at different frequencies.

Which amplitude and which frequency produces the louder, higher-pitched sound?

- A large amplitude and high frequency
- B large amplitude and low frequency
- C small amplitude and high frequency
- D small amplitude and low frequency

38 The current in a lamp is 0.25 A. The maximum safe current in the cable to the lamp is 5.0 A.

Which fuse should be used to protect the lamp circuit?

- A 0.2 A
- B 1.0 A
- C 5.0 A
- D 10.0 A

39 A student connects a battery to a lamp. She wishes to measure the current in the lamp and the potential difference across the lamp.

Which circuit is used to do this?

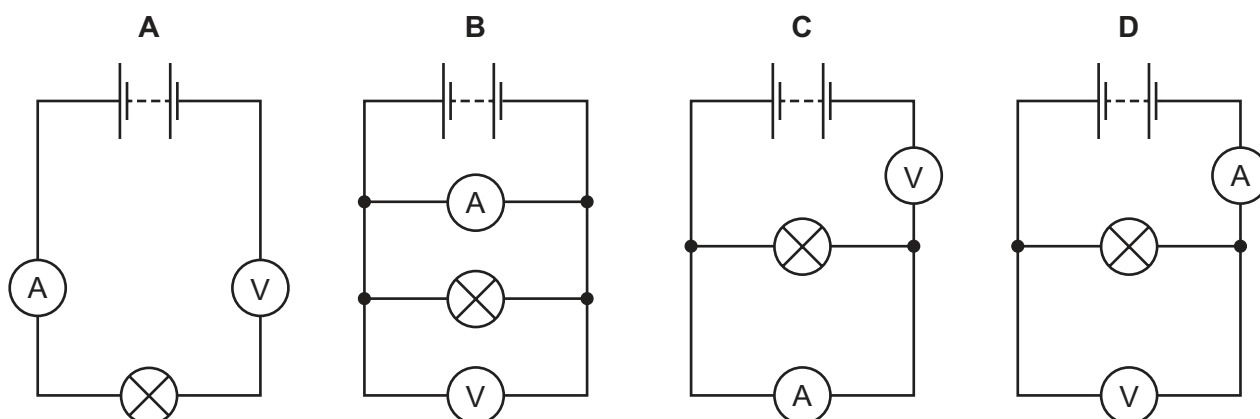

40 In the circuit shown, the switch is open.

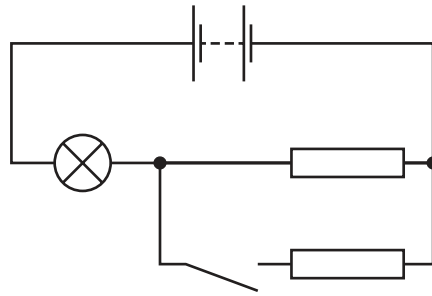

What happens to the lamp when the switch is closed?

- A It becomes brighter.
- B It becomes dimmer.
- C It becomes dimmer at first, then brighter.
- D Its brightness does not change.

